



PMc01A

PROFESSIONAL MIXING CONTROLLER

OWNER'S MANUAL

VESTAX CORP.

2-37-1 Kamiyama, Setagaya-ku, Tokyo 154

Phone: 03-3412-7011 Fax: 03-3412-7013

VESTAX MUSICAL ELECTRONICS CORP.

2860 Cordelia Rd. Suite 120 Fairfield, CA 94585 U.S.A.

Phone: 707-427-1920 Fax: 707-427-2023

VESTAX (Europe) Ltd.

18 St. Christopher's Road, Haslemere, Surrey GU27 1DQ England

Phone: (0) 1428-653117 Fax: (0) 1428-661021

CONGRATULATIONS!

Thank you for purchasing the VESTAX PMC-01A, Professional Mixing Controller.

Please read this owner's manual carefully before you start to use your mixer, so that you will fully understand all of the special features and enjoy the full use of the product.

[FEATURES]

- PMC-01A provides standard function of DJ Mixer, though the body is compact. 1 phono, 2 line inputs are provided to each program. Each input channel has a trim control for the setting of input levels. Two band EQ are also provided on each channel. And more, 1 mic input is also provided.
- Simple design is attained by removing screws around fader volumes and also playability is increased.
- Wood material is used at front panel of pmc-01 to achieve a warm sense of design.

IMPORTANT

To prevent electric shock, do not remove the cover. No user serviceable parts are inside. Please refer servicing to a VESTAX Authorized Service Center. Always disconnect all equipment from the main supply when disconnecting or reconnecting signal leads. The power cord should be connected last. Make sure that the power switch is off when connecting. Disconnect from AC supply when equipment is not used for extended amount of time.

WARRANTY

The warranty might vary from country to country. Each distributor has their own warranty system in accordance with the country or state regulations or laws. VESTAX observes the manufacturing country's regulations.

PRECAUTIONS

- *Humidity and dust
Avoid use where there is high humidity and dust which may cause damage to internal parts.
- *Temperature
Avoid use in hot, (over 35°C) and cold, (below 5°C) locations. Keep the unit away from extreme direct heat such as direct sunlight, heating radiators, or closed vehicles.
- *Power cord handling
Connecting the power cord to other cords or joining cords together can cause fire and electric shock. This is extremely dangerous.
Take precaution when handling AC plugs and connectors. Handle only the plug or connector and do not perform these operations with wet hands.
- *Keep away from liquids
Do not stand cans containing liquids on or near the equipment. If liquid enters equipment, disconnect the power cord from the power outlet immediately.

CONTROL AND FUNCTIONS

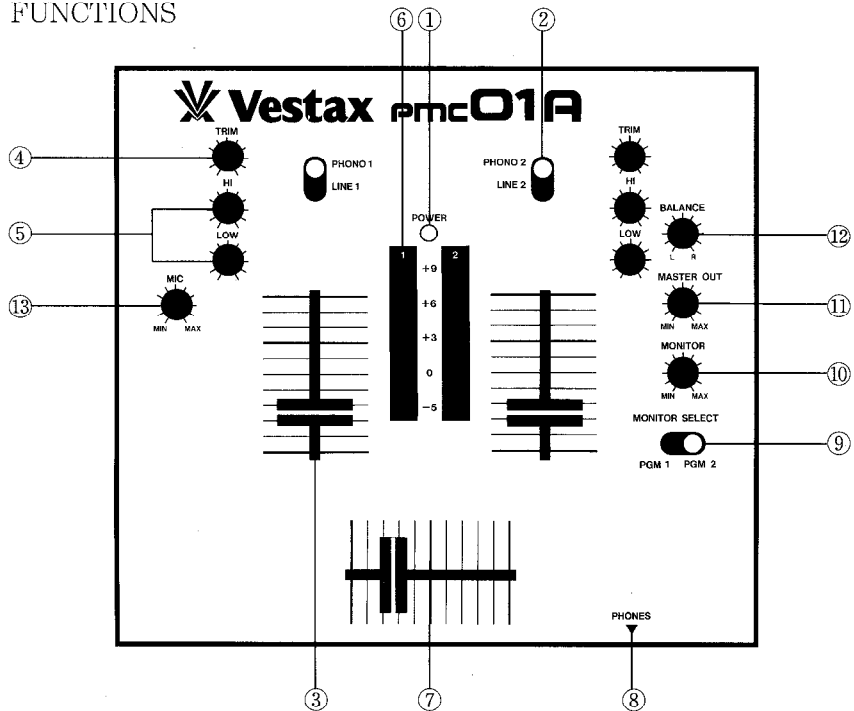

TOP PANEL

① POWER LED

The LED is lit when power is on

② INPUT SELECTOR

Used to select the input (two LINE or one PHONO) to be sent to each PGM channel.

③ INPUT FADER

Used to adjust the input level of each program. Usually set at the 7-8 position.

④ TRIM CONTROL

Adjusts the input level of each channel. Set INPUT FADER to 7-8 position, adjust TRIM so that the INPUT LEVEL METER shows about 0 dB.

⑤ EQ (HI, LOW)

Adjusts the HI and LOW frequencies for each PGM channel.

⑥ INPUT LEVEL METER

⑦ CROSSFADER

When the input level of PGM1 and PGM2 are properly set, PGM1 will be heard with the cross fader set to the left side. PGM2 will be heard with the cross fader set to the right side.

When the cross fader is set in the center, both programs will be heard.

This is a detachable fader for the ease of replacement with CF-01 when it is worn out.

How to replace the fader:

- Remove a each fader knob and four screws which fix the top panel.
- Remove the top panel.

- Remove four screws which hold the fader unit, and take the fader unit out.

- Carefully remove the multi-cable connector from the fader unit.

- Insert the connector to the new fader unit, and replace the fader unit and tighten the screws.

- Replace top panel and all fader knobs

⑧ HEADPHONE JACK

Use this jack to connect the headphones. Headphones from 8 ohm to 600 ohm can be used. 150 ohm is recommended

⑨ MONITOR SELECT SWITCH

Selects the PGM for monitoring. The monitor signal comes from "Pre-Fader". This means it will not be affected by the input faders, so that you can monitor an input signals without the sound coming from the line output.

⑩ HEADPHONE LEVEL

Adjusts the headphone output level.

⑪ MASTER LEVEL VOLUME

Adjusts the signal level output from the LINE OUT jack on the rear panel.

⑫ MASTER BALANCE VOLUME

Adjusts the signal balance of the left to the right side of the outputs from the LINE OUT jack on the rear panel.

⑬ MIC LEVE

Adjusts the input level from all microphone inputs.

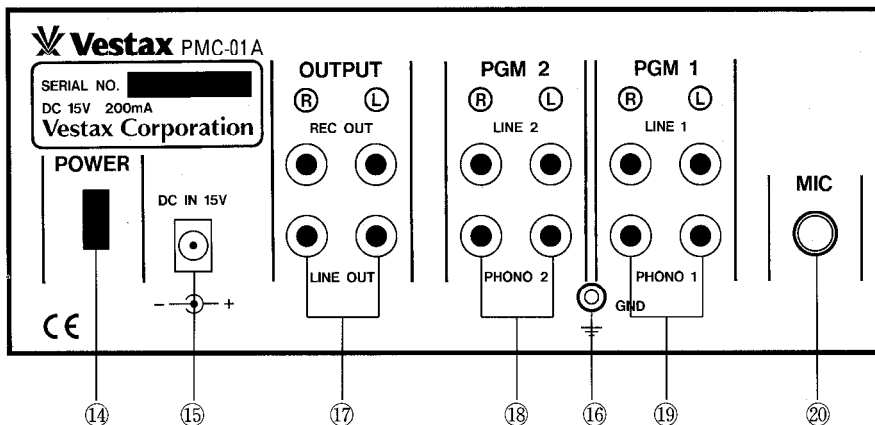

REAR PANEL

14 POWER SWITCH

The POWER LED that is located on the top panel is lit when on.

15 DC IN

Connect to the DC-15 AC adapter.

16 GND TERMINAL

Connect this terminal to the ground lead of the turntable. This helps to reduce noise and hum.

17 LINE OUT

Connect to the input of a power amplifier. You can also use another LINE OUT when you need to have an output besides the main output.

18 INPUT JACK 1

Used for input. Connect turntable equipped with a MM pickup cartridge to PHONO input. CD players, tape decks, DATs, MDs etc.. should be connected to LINE input. Line level musical instruments with stereo outputs such as Rhythm Machines or Samplers should also be connected to line inputs.

19 INPUT JACK 2

Used for PGM 2 input. Connect as for 18.

20 MIC INPUT JACK

Input jacks of MIC.

SPECIFICATIONS

● Nominal Input Level/Impedance	
PHONO	-42dB / 470k Ω
LINE	-10dBv / 470k Ω
MIC	-54dBv / 3.3k Ω
● Nominal Output Level/Impedance	
LINE OUT	-10dBV / 220 Ω
● Frequency Response	30Hz~20kHz (+0,-3dB)
● S/N Rati	\geq 82dB
● Dimensions (W×H×D)	187×165×69mm
● Weight	3.5kg